

HWAM053C-1

MANUAL OPERATION TABLE



HWAM053C-1

FEATURES AND HIGHLIGHTS

Technical parameters

▪ External size (LxWxH):	2000x480x(700-960)mm
▪ Head plate up/down:	45°/90°
▪ Back plate up:	0-80°
▪ Leg plate down:	0-90°
▪ Safe working load:	150kg

Technical configuration

<input checked="" type="checkbox"/> Arm support	2 pcs
<input checked="" type="checkbox"/> Leg support	2 pcs
<input checked="" type="checkbox"/> Body Support	2 pcs
<input checked="" type="checkbox"/> Shoulder Support	2 pcs
<input checked="" type="checkbox"/> Anaesthetic Screen	1 pc

Professional functions

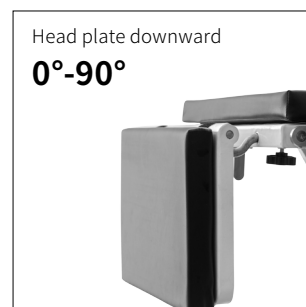
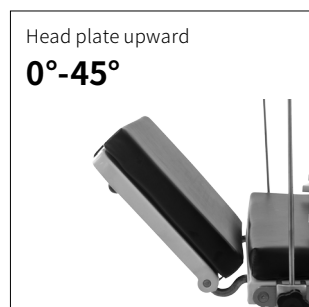
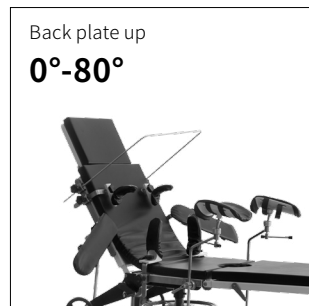

Material

Base structure is made of high-quality 304 stainless steel, robot welded with high strength and modern appearance. Table top is made of steel through epoxy painting, ASTM testing anti-bacterial.



Mattress

Removable memory mattress. Good resilience, anti-static, antibacterial, impact resistant.

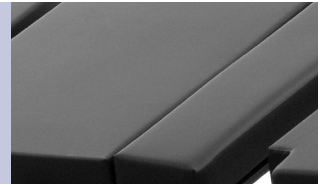

Control System

All the functions are manual controlled by screw and rack.

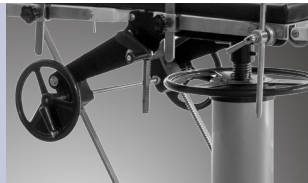

Structure

Full mechanical structure. Simple maintenance, low failure rate.

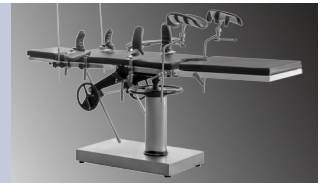

Leg board

Leg board can be folded down by adjusting the small handle. Leg board down: max. to 90°.

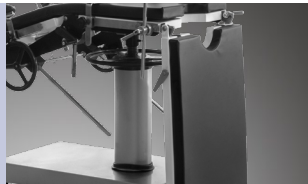

Armrest



Anesthesia Frame



Leg Crutches



Shoulder Support



Body Supporter

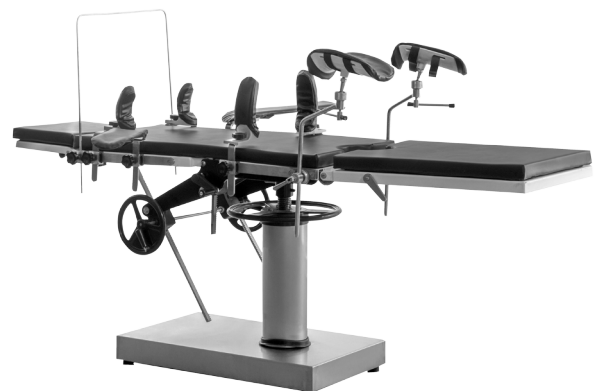

Healthward[®]

As the circumstance of printing, the photos might have minor difference on color, tactile from real products.
As the update of design and improvement, parameters and outlook of products might change, thanks for understanding.



 17800 CASTLETON ST STE 180.CITY OF INDUSTRY CA 91748

 +1 (603) 416-3063 ·  24/7

 export@health-ward.com

 www.health-ward.com



General catalogue